

22A  
**Drilling Attachment**

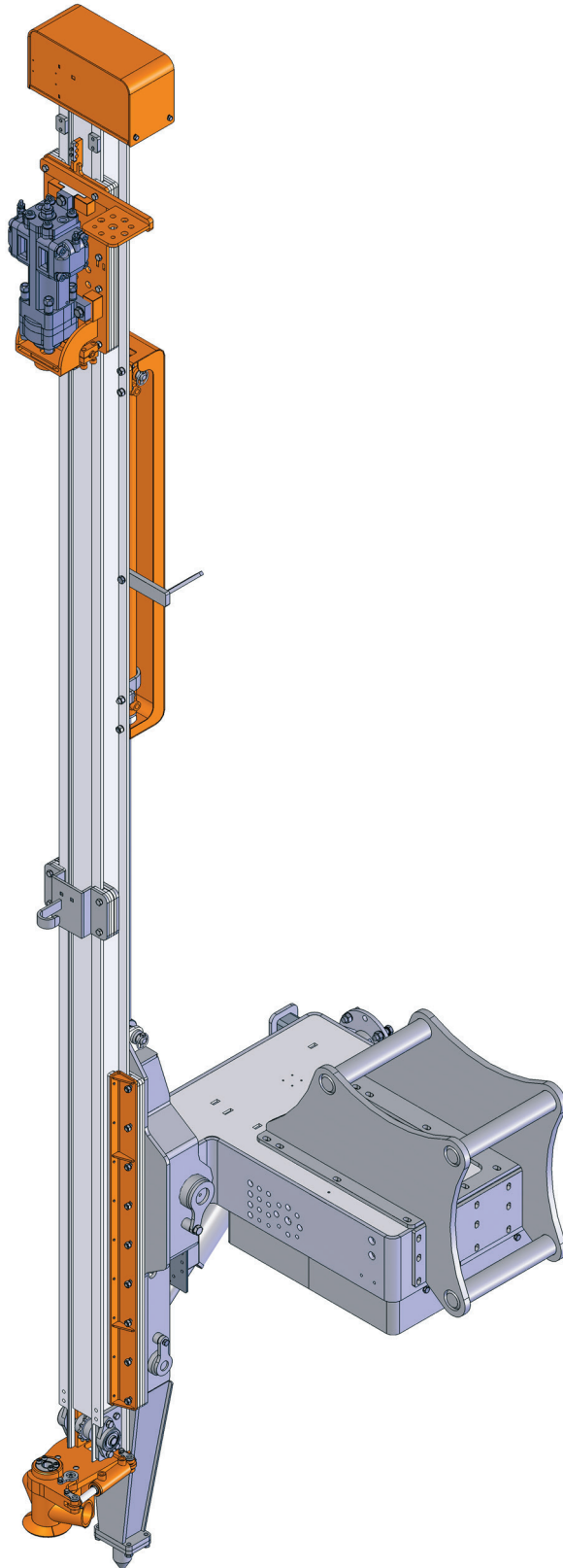

## Drifter

Manufacturer		Doofor
Type		DF430X
Impact power	kW	5,0
Max input power to rock drill	kW	9,3
Impact energy	J	60
Hydraulic pressure, max	bar	130
Torque, max	Nm	100
Impact frequency	Hz	100-115

## Dimensions and weights

Weight	kg	920 (w/o coupling)
Length	mm	5050
Width	mm	1200
Height	mm	1100 (w/o coupling)

## Drill Steel

Hole range	mm	30 - 41
Drill steel		7/8" - 1" / R25

## Dust collector

Model		ECON600
Filter area	m <sup>2</sup>	4,8
Number of filter elements	pcs	6
Suction capacity (max. nominal)	l/s	275
Suction hose diam	mm	76
Cleaning air pressure, max	bar	7
Cleaning air consumption	l/pulse	20

## Compressor

Type		Rotary vane
Model		HKL1300
Capacity	lpm	1300
Working pressure	bar	7

## Feed system

Feed extension	mm	1000
Feed force, max	kN	9,2
Tractive pull, max	kN	9,2
Total length	mm	5050

## AutoDrill drilling automatic system

Pressure adjustments during drilling	standard
X / Y angles with lights and numbers	standard
Penetration rate	standard
Hole depth	standard
Stop depth form surface	standard
Stop depth from laser level	option
Reading of hydraulic oil temperature	standard

## Accessories

Boom camera	option
Laser receiver	option
Central lubrication system	option
Extra mounting kit for additional excavator	option
GPS system	option

## Hydraulic system

Controls	AutoDrill automatic drilling with CAN-control from excavator cabin
Anti-jamming	Anti-jamming integrated in AutoDrill automatic drilling in all models
Oil cooling	Cooler for compressor motor return flow is available

## Carrier requirements

Weight	tn	9 - 21
Flow / pressure for drilling	LPM @ Bar	85 @ 150
Flow / pressure for compressor	LPM @ Bar	40 @ 150
Flow / pressure for dust collector	LPM @ Bar	25 @ 150
Total flow / pressure; min	LPM @ Bar	130 @ 150
Total flow / pressure; max	LPM @ Bar	150 @ 150
Power requirement for engine	kW (min/max)	42 / 47