

25A
Drilling Attachment

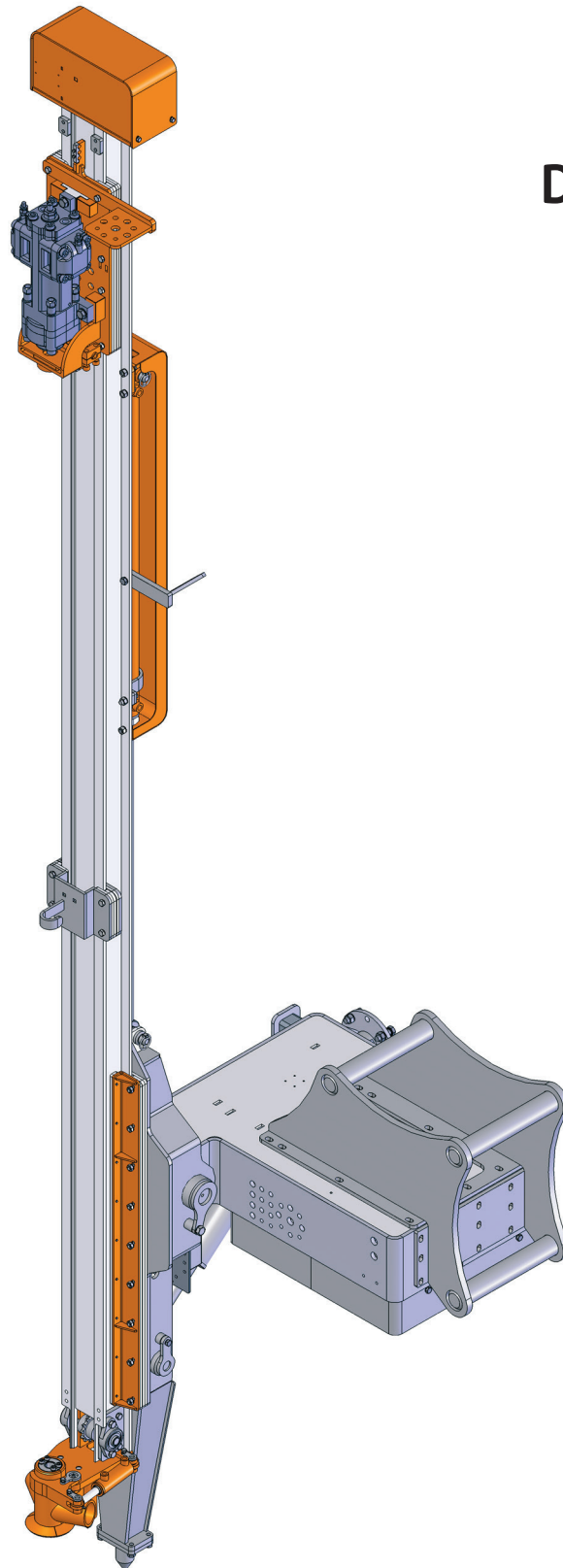

Drifter

Manufacturer		Doofer
Type		DF500X
Impact power	kW	10,0
Max input power to rock drill	kW	17
Impact energy	J	105
Hydraulic pressure, max	bar	130
Torque, max	Nm	110
Impact frequency	Hz	75-95

Dimensions and weights

Weight	kg	920 (w/o coupling)
Length	mm	5050
Width	mm	1200
Height	mm	5000 (w/o coupling)

Drill Steel

Hole range	mm	30 - 45
Drill steel		7/8" - 1" / R25

Dust collector

Model		ECON600
Filter area	m ²	4,8
Number of filter elements	pcs	6
Suction capacity (max. nominal)	l/s	275
Suction hose diam	mm	76
Cleaning air pressure, max	bar	7
Cleaning air consumption	l/pulse	20

Compressor

Type		Rotary vane
Model		HKL1300
Capacity	lpm	1300
Working pressure	bar	7

Feed system

Feed extension	mm	1000
Feed force, max	kN	9,2
Tractive pull, max	kN	9,2
Total length	mm	5050

AutoDrill drilling automatic system

Pressure adjustments during drilling	standard
X / Y angles with lights and numbers	standard
Penetration rate	standard
Hole depth	standard
Stop depth form surface	standard
Stop depth from laser level	option
Reading of hydraulic oil temperature	standard

Accessories

Boom camera	option
Laser receiver	option
Central lubrication system	option
Extra mounting kit for additional excavator	option
GPS system	option

Hydraulic system

Controls	AutoDrill automatic drilling with CAN-control from excavator cabin
Anti-jamming	Anti-jamming integrated in AutoDrill automatic drilling in all models
Oil cooling	Cooler for compressor motor return flow is available

Carrier requirements

Weight	tn	10 - 21
Flow / pressure for drilling	LPM @ Bar	90 @ 150
Flow / pressure for compressor	LPM @ Bar	40 @ 150
Flow / pressure for dust collector	LPM @ Bar	25 @ 150
Total flow / pressure; min	LPM @ Bar	140 @ 150
Total flow / pressure; max	LPM @ Bar	170 @ 160
Power requirement for engine	kW (min/max)	45 / 60